

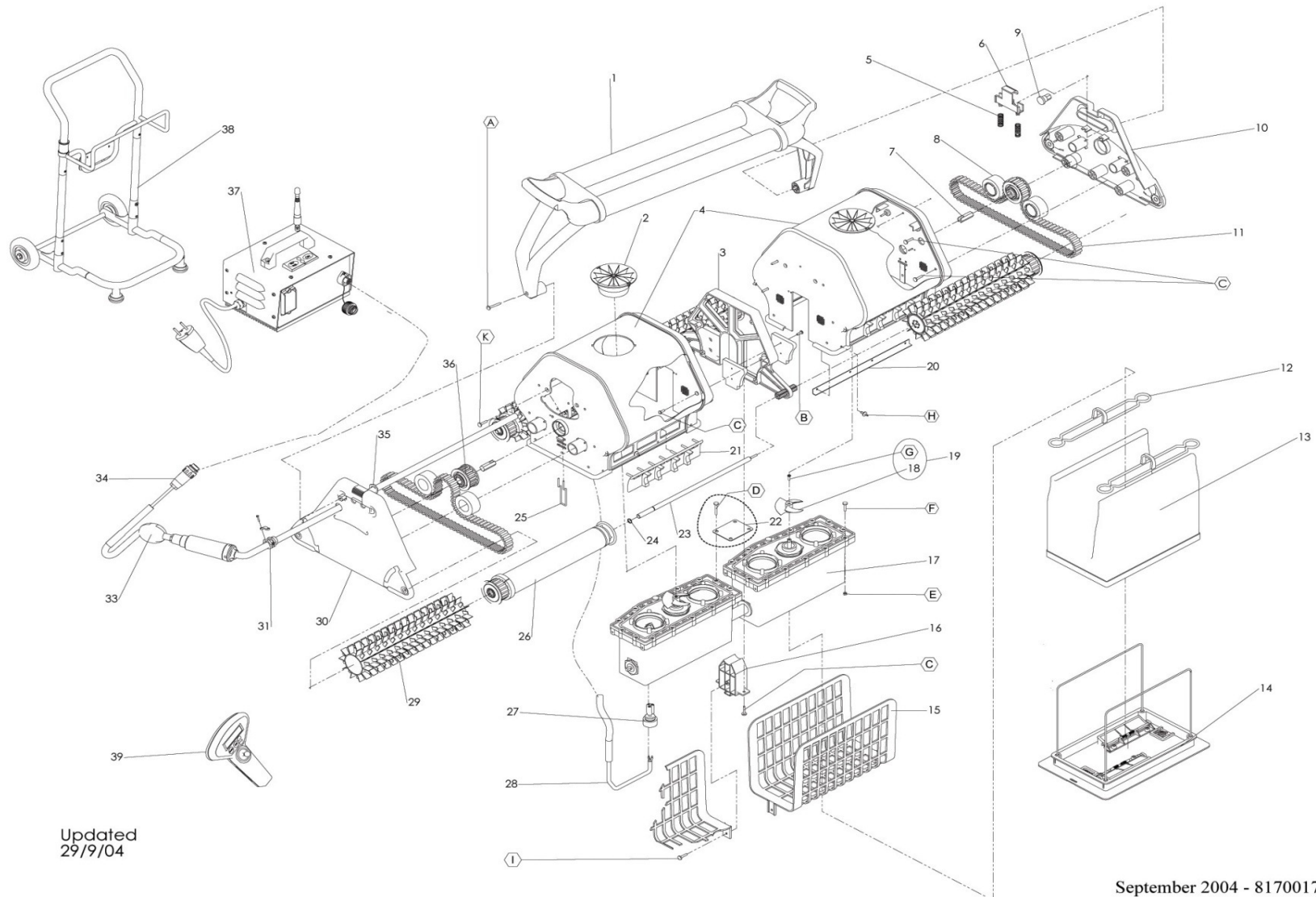

# ILLUSTRATED BILL OF MATERIAL AND DISTRIBUTOR PRICE LIST: DOLPHIN 2x2 (999351)



Updated  
29/9/04

September 2004 - 8170017

# BILL OF MATERIAL

## 9999351 - DOLPHIN 2x2

Number	Child Part Number	Part Description	DIY	MSRP
1	9995704	HANDLE BLACK FOR DOLPHIN - 2X2	Y	\$38.00
2	9995070	IMPELLER TUBE-YELLOW	Y	\$7.00
3	9987602	DIVIDER FOR 2X2	Y	\$5.40
12	9981430	FILTER BAG CLIP	Y	\$2.29
13	9995430-ASSY	FILTER BAG	Y	\$69.99
13	9991440-ASSY	DISPOSABLE FILTER BAG -PACK OF 5	Y	\$60.00
13	9995431-ASSY	COARSE FILTER BAG	Y	\$49.99
14	9995550	BOTTOM LID ASSY+SUPPORT (2005)	Y	\$49.00
15	6203703	FILTER SCREEN	Y	\$13.40
19	9995269	IMPELLER+SCREW DC	Y	\$9.40
29	6101603	PVC BRUSH DIAG - BLUE	Y	\$39.99
37	9995628LF	POWER SUPPLY - 2X2-DC 115V	Y	\$405.00
39	9995438	RCU 2X2 - 2004 VERS.	Y	\$293.00